



ELMECA

Elmecca Works & Office : Behind Railway Station, Post Box No. 17, Dharwad - 580007, (Karnataka), India
 Phone: 0836-440177 / 440178 / 440179. Fax: 0836-742600 & 743600 Email: elmecca@bgl.vsnl.net.in

ELMECA End Mill Holders with H - 30 Taper (MITR) R8

MITR Accessories (H 30 Taper)

These accessories are suitable for use on milling machines model MITR made by HMT. Collets to suit the above accessories are readily available ex-stock.

These accessories are being used as original equipment by HMT for their MITR Milling Machines.

Arbors are manufactured from high quality case-hardened alloy steel.

Arbors are manufactured as per I.S. No. 2169-1963 with a slight modification - instead of providing a separate driving collar, screwed dogs are provided.

Arbors for SANDVIK face milling cutters are also manufactured on special requests and provided that the quantity ordered is not small.

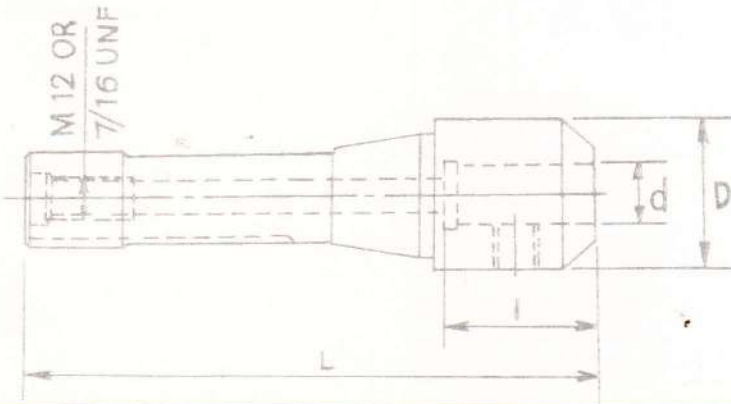
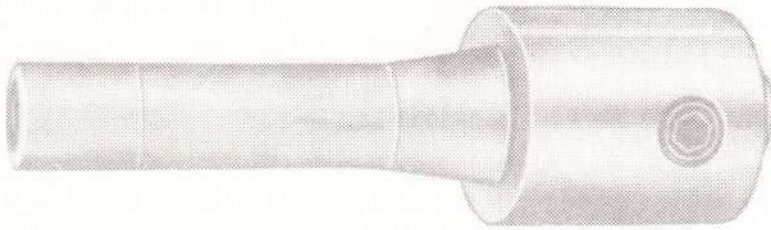

Elmecca Endmill Holders :-

These end mill holders are also used for straight shank cutters like Collets. But the use of these is preferred when close tolerances are to be achieved. Unlike Collets, the clamping is effected by a grub screw on the flat of the cutter shank. Due to this feature the out-running of the cutter is reduced to the minimum and heavier cuts are possible. Design of these holders also facilitates the use of cutters upto 25 mm/1" in diameter. Standard sizes available are 4, 5, 6, 8, 10, 12, 16, 20 & 25mm/3/16, 3/8 1/2, 5/8, 3/4, 7/8 & 1". Other accessories which are available for use on MITR milling machine are adaptors with standard E-40 or 'M' Series Collets. Boring heads Elmecca 160 & 260, Milling fixture-indexing and non-indexing types. The details of the same are available in the catalogue elsewhere.

Code No	d"	D	I	L
EH 30.3/16	3/16	31	26	132
EH 30.1/4	1/4	31	26	132
EH 30.3/8	3/8	31	26	132
EH 30.1/2	1/2	32	44	150
EH 30.5/8	5/8	40	44	150
EH 30.3/4	3/4	50	64	170
EH 30.7/8	7/8	50	64	170
EH 30-1"	1	50	64	170

Code No	d"	D	I	L
EH 304	4	31	26	132
EH 305	5	31	26	132
EH 306	6	31	26	132
EH 308	8	31	26	132
EH 3010	10	31	26	132
EH 3012	12	32	34	140
EH 3016	16	40	44	150
EH 3020	20	50	64	170
EH 3025	25	50	64	170

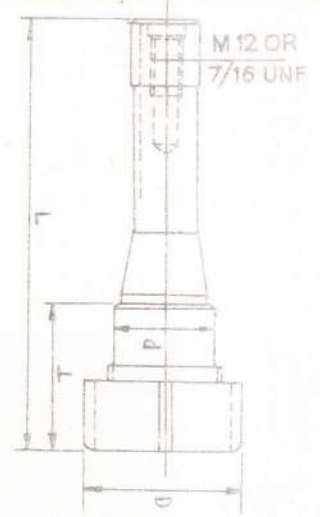

Milling adaptor with H 30 Shank (MITR)

Code No.	Capacity	L	I	D	d	Collet Type
AEH 3032	2-20	165	50	38	50	E 32
AEH 3040	3-25	170	60	48	65	E 40
AMH 3016	2-16	170	60	38	52	M 16
AMH 3025	3-25	170	65	47	63	M 25
AGH 30 I	1-22	185	70	44	44	AG I

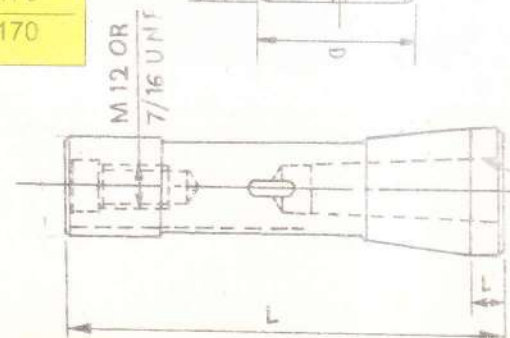

ELMECA Shell End Mill arbors with H30 Taper (MITR) R8

MITR Accessories (H 30 Taper)

These accessories are suitable for use on milling machines model MITR made by HMT. Collets to suit the above accessories are readily available ex-stock.

These accessories are being used as original equipment by HMT for their MITR Milling Machines.

Arbors are manufactured from high quality case-hardened alloy steel.

Arbors are manufactured as per I.S. No. 2169-1963 with a slight modification - instead of providing a separate driving collar, screwed dogs are provided.

Arbors for SANDVIK face milling cutters are also manufactured on special requests and provided that the quantity ordered is not small.

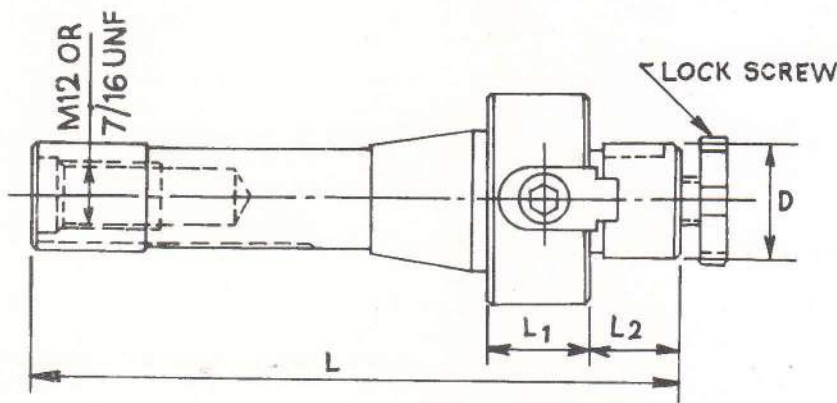
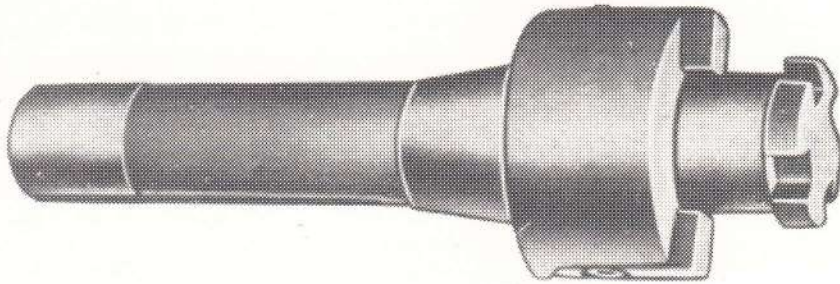

Code No	D	L1	L2	L	Lock Screw
SH 30-13	13	10		140	M6
SH 30-16	16	23	17	146	M8
SH 30-22	22	23	19	148	M10
SH 30-27	27	25	21	152	M12
SH 30-32	32	26	24	156	M16
SH 30-1/2	1/2"	19	15	140	M6
SH 30-3/4	3/4"	24	18	148	M10
SH 30-1	1"	26	18	150	M12

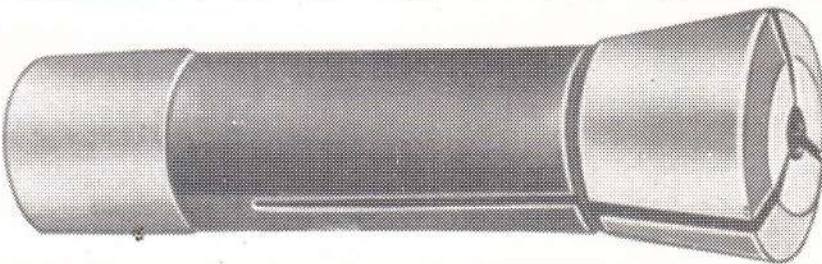

Elmeca Reduction Sockets :-

These are also called adaptors for taper shank tools. These sockets can take up MTO, MT1 and MT2 tools having tangs. MT1 and MT2 are standard and are available stock.

Elmeca Shell end mill holders :-

These holders are used with shell end mills. Standard sizes available are 13, 16, 22, 27, & 32mm/1/2, & 1 1/4". These are made of alloy case hardening steel and case hardened.

Other accessories which are available for use on MITR milling machine are adaptors with standard E-40 or 'M' Series Collets, Elmeca Boring heads 162 and 260, Milling fixture-indexing and non-indexing types. The details of the same are available in the catalogue elsewhere.

Collets :-

Elmeca Collets are used for straight shank cutters. Standard sizes available in stock are 4, 5, 6, 10, 12 & 16/1/8, 3/16 1/4, 3/8, 1/2 & 5/8 but on request any other size can also be supplied. The maximum capacity of these Collets is 16mm/5/8".



keeping in step with today's technological strides, we make improvements in the designs of our products. Hence the product supplied may have features different from those described in this bulletin.

ELMECA WORKS (Prop. Pelma Engg. Indus. Pvt. Ltd.)

Works & Office : Behind Railway Station, Post Box No. 17, Dharwad - 580007, (Karnataka), India.
Phone: 0836-440177 / 8 / 9. Fax: 0836-742600 & 743600, Email: elmeca@bgl.vsnl.net.in

Mumbai Office : 170 / 2 Jot Society, Jyotiba Phule Road, Dadar (E), Mumbai 400 014, India.
Phone: (022)-413 1213 & 413 5746 . Fax: 022-413 1213 Email: tejina@bom8.vsnl.net.in